

Liquid ring vacuum pumps

AWL 6000 – AWL 37500

Atlas Copco



Atlas Copco AWL liquid ring vacuum pumps feature single stage design for outstanding performance and durability at high capacity ranges.

Atlas Copco AWL liquid ring pumps are ideal for pumping dry or wet gasses, with a high tolerance to liquid carryover, especially in condensable processes. The AWL range of pumps offer economical vacuum solutions to processes with high flow requirements at vacuum pressures down to 160 mbar(a).

The series can be customized to your specific requirements. Stainless steel and coating options make these units ideal for filtration, evacuation and evaporation duties in the toughest environments such as mining and minerals, sugar production, timber impregnation, and pulp and paper.

Features and benefits

- Simple single stage operation principle
- Flanged center body for strength
- Very high suction capacities
- V-Belt or Gearbox drive options
- Very low maintenance requirement
- Exceptional vapor / humidity handling
- Stable self-regulating performance
- Compact economic installation
- Materials of construction: carbon steel, ductile SG iron, stainless steels, epoxy and ceramic coatings
- High efficiency IE3 motor drives as standard

Technical specifications

	AWL 6000	AWL 7800	AWL 8500	AWL 10500	AWL 10800	AWL 13500	AWL 15500	AWL 17500	AWL 22800	AWL 30000	AWL 37500
Process DN	250	300	250	300	350	350	400	400	500	500	500
Nominal rpm	440	372	440	372	372	312	266	266	246	266	236
Nominal capacity (m ³ /h)	5400	6050	6800	8350	9450	11500	13500	15800	21200	26000	28050
Ultimate pressure (mbar(a))	160	160	160	160	160	160	160	160	160	160	160
Nominal installed motor (kW)	90	100	117	133	150	165	190	237	332	425	460
Block dimensions (L x W x H) (mm)	1985 x 1110 x 1570	2170 x 1370 x 1865	2135 x 1110 x 1570	2540 x 1370 x 1865	2435 x 1550 x 2160	2655 x 1550 x 2160	2370 x 1750 x 2560	2980 x 1750 x 2565	3185 x 2050 x 2965	3445 x 2050 x 2965	3655 x 2050 x 2965
Dry weight (kg)	3250	4700	3600	5000	6600	7100	10700	11300	14700	15900	17000

Performance range

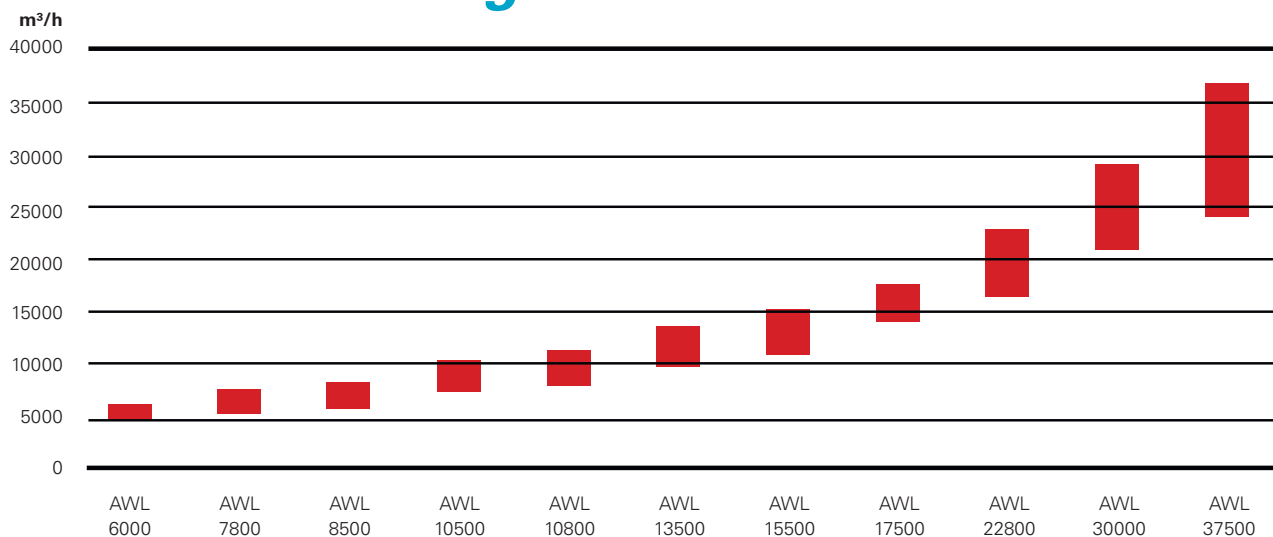

Dimensions

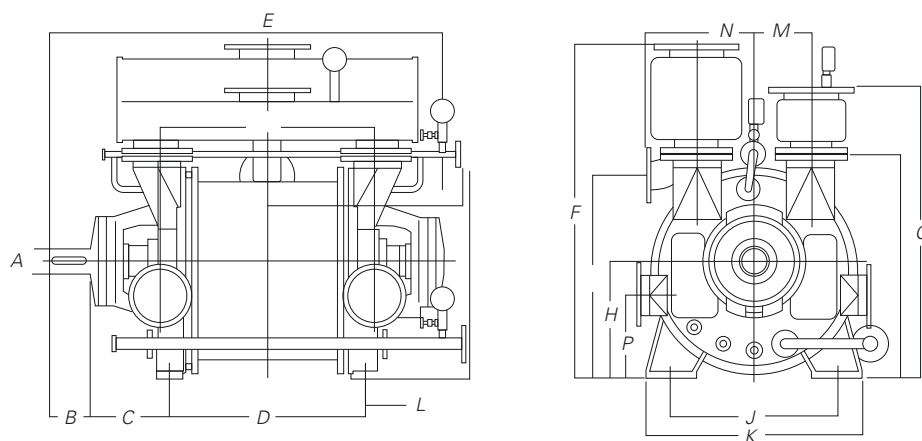

	AWL 6000	AWL 7800	AWL 8500	AWL 10500	AWL 10800	AWL 13500	AWL 15500	AWL 17500	AWL 22800	AWL30000	AWL37500
A	120	140	120	140	160	160	180	180	200	200	200
B	165	200	165	200	240	240	240	240	280	280	280
C	335	355	335	355	375	375	400	400	450	450	450
D	1150	1110	1300	1480	1450	1670	1700	1950	2020	2280	2490
E	1985	2170	2135	2540	2435	2655	2730	2980	3185	3445	3661
F	1570	1865	1570	1865	2160	2160	2560	2560	2965	2965	3055
G	1050	1625	1050	1625	1875	1875	2220	2220	2560	2560	2560
H	560	670	560	670	800	800	950	950	1120	1120	1120
J	800	950	800	950	1120	1120	1320	1320	1600	1600	1600
K	1110	1370	1110	1370	1550	1550	1750	1750	2050	2050	2050
L	35	42	35	42	42	48	48	48	48	48	48
M	285	335	285	335	385	385	435	435	490	490	490
N	530	620	530	620	670	670	805	805	860	860	860
P	395	475	395	475	560	560	665	665	790	790	790

All dimensions in mm.



www.atlascopco.com/vacuum